

STAIR-GLIDE®

Stairway Lift

Unit Dimensional Drawing

SPECIFICATIONS

Rated Load: 300 pounds (135kg)
 Speed: 25 fpm (0.13 ms)
 Travel: 60' max. (18.2m)
 Power Supply: 115 VAC, 60 Hz, 3-wire grd outlet
 Incline Limts: 25° to 45°
 U.L. and c/U.L. listed

STANDARD EQUIPMENT

Drive System: Rack and pinion
 Motor: 1/2 hp, 120 VDC, 60 Hz (reversible)
 Motor Controller: SoftStart
 Brake: Self-locking worm gear
 Rail: 2⁵/₈" wide steel beam
 Rail Length: 16' stock or custom cut
 Rail Finish: Ivory white powder coat
 Upholstery: Plum, teal, wheat or smoke fabric;
 taupe, misty gray or sable brown vinyl
 Seat: 18" wide seat with two straight fold-up
 arms and 60° / 90° locking swivel
 seat at the top landing
 Controls: Constant pressure up-down controls in
 ends of arms and call/send controls
 Safety Devices:
 Footrest obstruction sensors
 Seatbelt
 Swivel seat cut-off switch
 Warranty: Five years on drive train and two years
 on all component parts

OPTIONAL EQUIPMENT

Wraparound arms, folding
 Upholstered hand rests for wraparound arms
 Hand-held pendant control
 Joystick control on arm
 Wireless call/sends (RF)
 Final limit switch - top and bottom landing
 Manual lowering device (hand crank)
 Key switch on call/send controls and unit
 Key switch on unit only
 Overspeed brake
 Folding rail - manual
 Folding rail - power
 Public Building Package (key switch on call/send
 controls and unit, overspeed brake, operation
 plaques and fire warning decals)

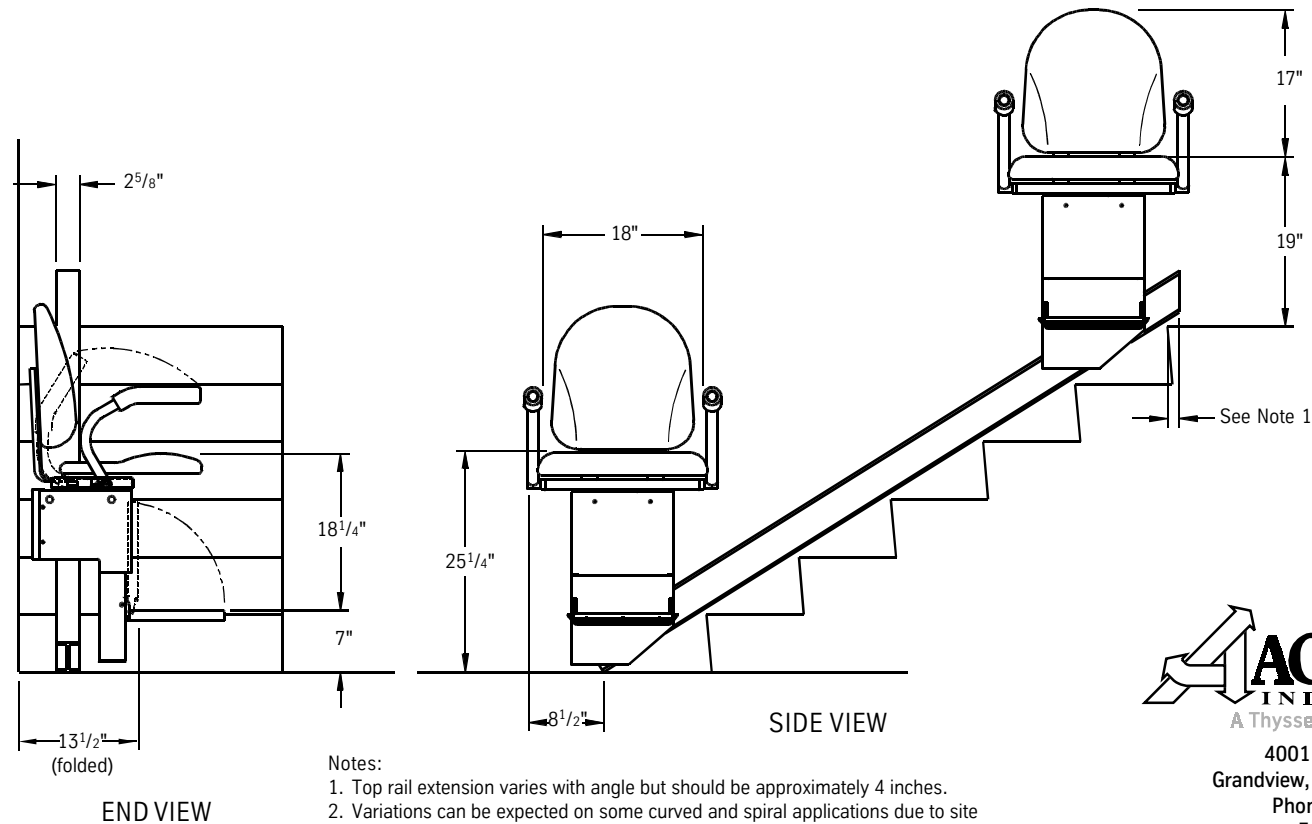
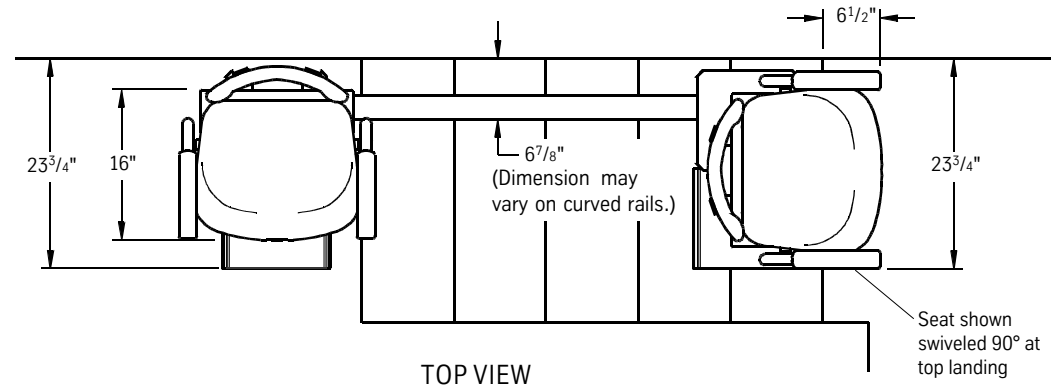

Notes:

1. Top rail extension varies with angle but should be approximately 4 inches.
2. Variations can be expected on some curved and spiral applications due to site considerations regarding track fit and seat/footrest location.



4001 East 138th Street
 Grandview, MO 64030-2837
 Phone: 816-763-3100
 Fax: 816-763-4467
 Toll Free: 800-669-9047
 www.accessind.com